



Schindler renovation package

Effective solutions for ageing elevators



Signs of age? Try our revitalization solution

Reliability

Durable mechanical parts and intelligent electronic diagnostics, all in line with the latest safety standards, ensure a safe ride, with a minimal risk of remaining stuck in the elevator.

Availability

Maintenance-friendly solutions and remote monitoring significantly reduce the likelihood and complexity of interventions - increasing your elevator's availability to the level of a new one.

New features

Better aesthetics, more intuitive controls, reduced noise and increased ride comfort all enhance the user experience.

Professionalism

We offer high-quality consulting and support for decision-making and planning plus quick, clean installations by our highly professional workers - leading to minimal disturbances.



Key Specifications

Usage	Residential / Commercial buildings
Speed	Up to 1.0 / 1.6m/s
Nr. of stops	15 / 21 stops
Car entrances	1 or 2
Main parts	Control and main wiring, drive, frequency converter, fixtures
Options	Machine and traction media Sensors and communication system Car decoration and illumination Car and landing door updates Safety components

Schindler makes your elevator young again

The Schindler Renovation Package is a performance upgrade for your elevator making it highly reliable and available.

Want something more? Give your elevator a makeover and install the latest features in elevator technology.

Need support? Our professionals guide you throughout the whole process from analysis to handover.

Reliability

Schindler solutions get rid of the unreliability associated with older installations, ensuring a safe and secure ride, with minimal risk of remaining stuck in the elevator.

Worn out, unsafe and non-compliant components are replaced with strong, durable mechanical parts and intelligent, electronic diagnostics.

What's more, by installing all these new components, the latest norms and regulations, created to make your elevator ride as safe as possible, can now be easily fulfilled by your elevator.



Availability

For the users of your building, elevator availability is a top priority.

Schindler solutions are long-lasting, lubrication-free, self-diagnosing and maintenance-friendly, while remote online monitoring means our technicians can even act before an error appears.

All this means less frequent and more efficient interventions, leaving your elevator far more available for your users.

24/7



New features

With a Schindler upgrade, the whole experience of using your elevator becomes smoother and more pleasant. In the first place, intuitive controls, clear displays and informative messages make it easier to operate. Better accessibility, aesthetics and illumination make the car a more pleasant environment, while reduced noise, increased comfort and stopping accuracy all further enhance the user experience.

At the same time, energy efficiency and sustainability improvements reduce your carbon footprint and impact positively on your bottom line.



Professionalism

Schindler provides high-quality consulting, support and coordination for decision-making, planning and implementation of your chosen solution. From analyzing your existing elevator and evaluating alternative options to order handling, installation and testing a modernization package. Our mission is to ensure every step in the process runs smoothly and efficiently. With highly-trained workers who operate quickly, cleanly and with minimal disturbance to the everyday life of your building.



Improvements on every level



Machine and traction media

The force and power of the elevator

- minimum noise
- robust / long life
- low energy consumption
- smooth and fast ride

Controller, frequency converter and wiring

The brain and core of the elevator

- new controller functions increase reliability and safety
- durable and quiet
- frequency inverter for a smooth start/stop and perfect levelling
- New wiring guarantees perfect connections and functionality of electrical components

Energy

Optimized power consumption

- PF1 inverter for energy recuperation
- reduced energy consumption of new components
- selective standby mode
- LED lighting with long lifetime and low consumption

Sustainability

Commitment for a sustainable future

- ecologically responsible production and material usage
- optimized packaging and logistics
- low-wear components and efficient maintenance
- proper disposal of materials

Sensors and doors

The entrance portal to the transport facility

- reliable door drives increase availability
- door drive runs smooth and quiet
- built-in sensors contribute to reliability and a long service life

Cladding and illumination

The face and clothing

- brilliant lighting
- durable wall materials
- large selection of colors and combinations

Fixtures in car and landing

The steering wheel and navigation bridge

- contemporary design
- user-friendly, clear communication and indication
- in line with latest regulations

Safeties

The guardian angel – keeps you secured

- updates to fulfill the latest regulations
- full door height light curtain – immediate door reopening in case of interruption
- precise levelling to avoid trip hazards
- safety devices like overspeed governor to guarantee safe stop in any emergency situation

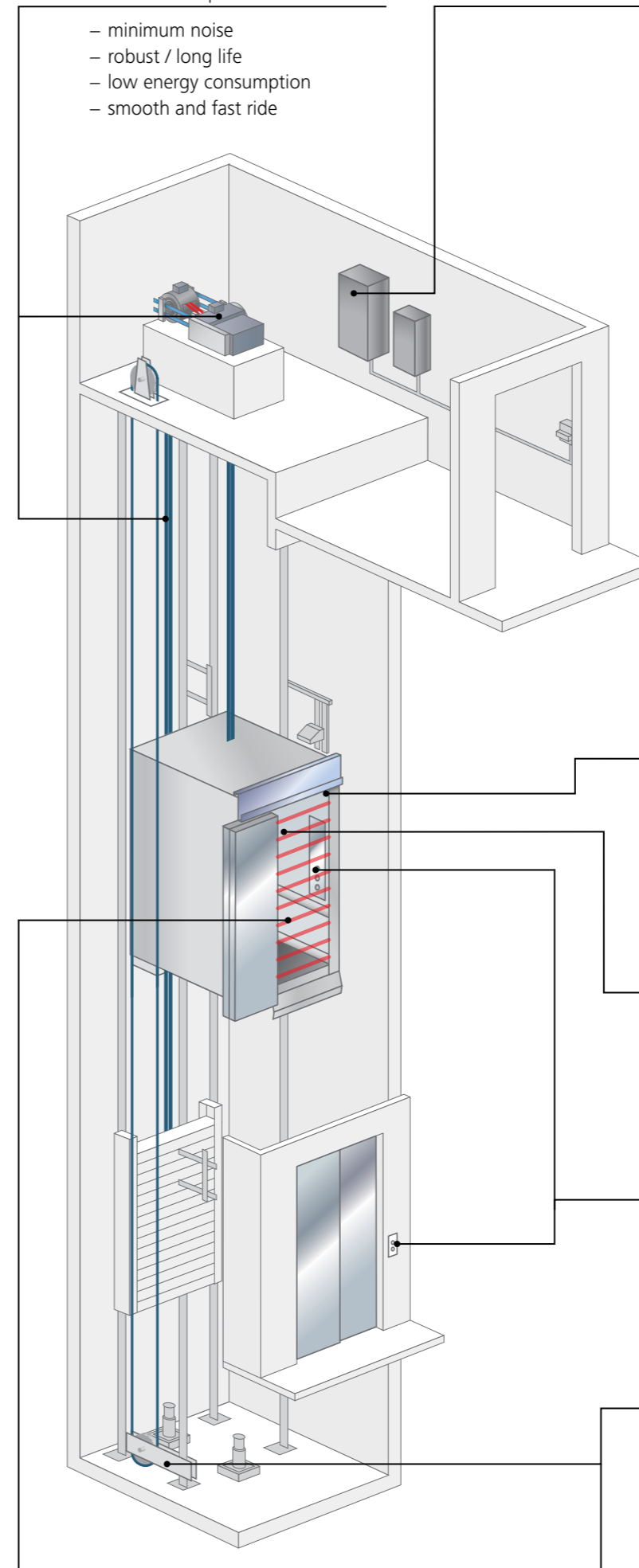

Improved interior design

Make your elevator not only run like new but also look like new. Modern design fixtures and a wide selection of design lines, combined with new ceilings including LED lighting, full height mirror, handrail, and PVC or artificial granite floor complete the perfect choice.

Car claddings

A wide selection of design lines gives you the freedom of choice. Select walls, ceiling and floor to match your building.

Lighting

The square lamp uses LED lights with an extremely long service life, up to 20 times longer than standard light bulbs, while consuming less energy.

Mirror

One side wall or the rear wall can be provided with a full-length mirror of safety glass.

Handrail

The painted aluminum handrail enhances comfort and safety in your car. It can be mounted on a side wall or the rear wall.

Operating panels

Make your elevator easy to operate for all passengers. Energy-efficient operating panels all come in high quality materials and finishing. As an option, elegant full-glass fixtures provide the final touch to the car interior. High-resolution and easy-to-read indicators make the ride even more enjoyable.

For a complete overview of all fixtures and options, see our separate decor lines brochure.



Square ceiling lights

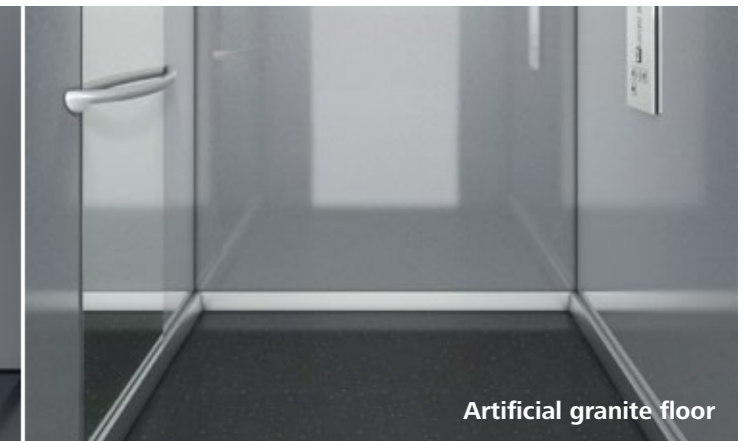

Artificial granite floor

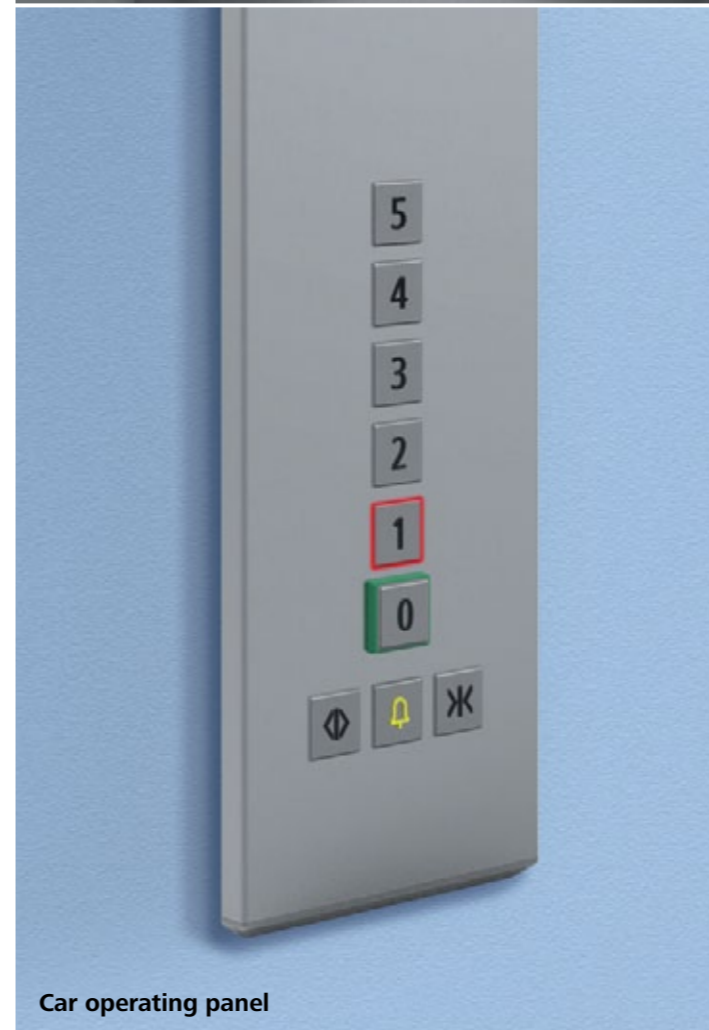

Car operating panel

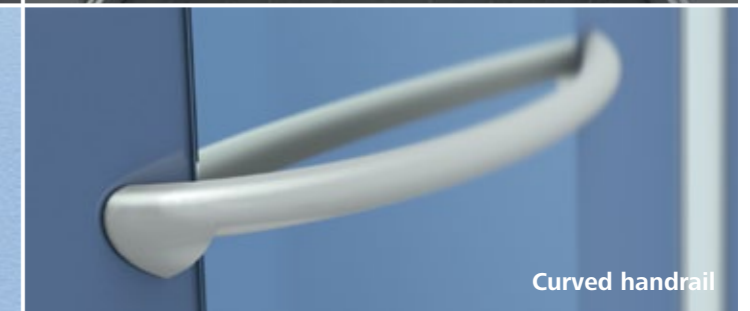

Curved handrail



Full height mirror



Key switches

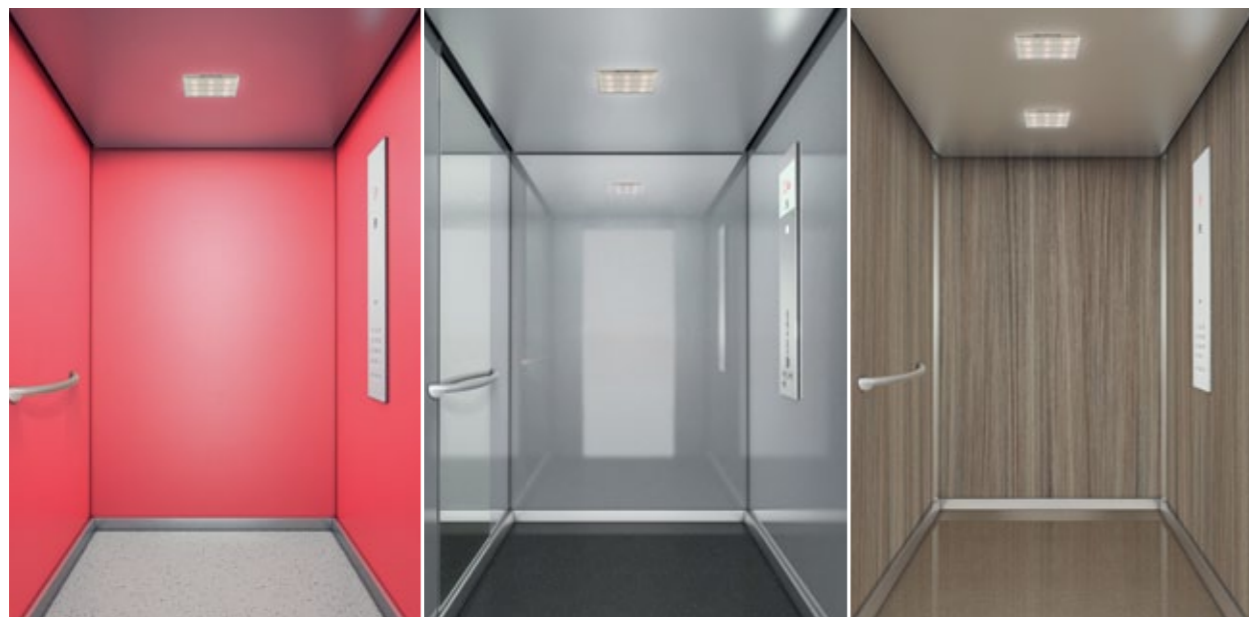

The professional way to move up



1. Elevator analysis

Inspection of components and availability
 Schindler modernization specialists will examine all the mechanical and electronic components of your existing elevator installation, to ensure safe and reliable operation of your equipment. For example, are the traction sheaves or traction ropes worn out? Is the elevator machine losing oil? The condition of all equipment is summarised in detail. They will also inform you of any parts which may no longer be available and any new regulations that you may wish your equipment to satisfy.

2. Overall evaluation

Finding a solution
 The overall evaluation indicates the key areas that may require attention in order to provide you with optimum performance: short-term repairs to be carried out, medium-term planning for modernization or a replacement system. Our modernisation specialists will advise you on the range of solutions available so that together we can identify the right option for you.

3. Advice and planning

Budget planning and organization
 Working together, we can determine the best solution for you and your equipment. If you decide on a modernization or replacement system, our sales technicians can also assist you with budget planning and the organization of building-related services (electricians, contractors, machine fitters, etc.). With our professional order tracking system and detailed progress updates, we will keep you informed about every step of the way.

4. Logistics

Ordering, manufacturing and delivery
 The efficiency of our process ensures all the right elements are in the right place at the right time, with no wasted time or energy. Once the contract has been awarded, your chosen solution will be ordered, manufactured and delivered directly to your site after approval of the installation plan. To ensure a smooth installation process, we'll meet with you a few weeks before the installation date to discuss the final program of works and also the interface you may require us to have with any other services. We will also clarify accessibility, define any storage space required for materials and coordinate our activities with any subcontractors on site.

5. Installation

On-time installation
 Satisfying your program of works is our top priority. To ensure this happens, we will provide you with regular updates on the project's progress. Our highly trained personnel endeavor to keep any noise, disruption or dirt caused by the installation to a minimum, always showing the utmost respect for your building and its users.

6. Handover

Technical approval and handover of the system
 The installation of your system is only considered complete when the lift satisfies all of the prescribed safety and performance criteria. Qualified specialists follow a comprehensive technical approval process to verify the compliance with all requirements. Once approval has been successfully achieved, the system will be handed over to you.

When vision meets discipline. Schindler partners with Solar Impulse.



Schindler is a main partner of **Solar Impulse**, the zero fuel airplane aiming to fly around the world propelled only by solar energy.

Schindler Management
PLM-MOD
Zugerstrasse 13
6030 Ebikon
Switzerland

Telephone: +41 41 445 31 31
Fax: +41 41 445 39 11

www.schindler.com



**Find more information on
Schindler products.**

Just scan the code with your mobile phone,
using free QR code scanner software.
This is either pre-installed on your phone or
easily downloadable for free.