



## Schindler 5400

Top quality has a name.

Our high-capacity passenger elevator  
for office buildings.





# Versatility



**The Schindler 5400 is equal to any task.**

The system is built to meet your expectations, regardless of whether it is just one elevator for an office building, or a major project for an airport that is required – with standard or custom-made interior design – this elevator leaves nothing to be desired.



**The Schindler 5400 communicates generosity.**  
We use the available space optimally, both horizontally and vertically. Every last detail is custom-made. With this elevator, it's easy to accomplish more.

A photograph of a modern building interior. In the background, a glass door is partially open, revealing a staircase. On the floor in the foreground, a white bucket lies on its side, surrounded by several white balls. The floor is light-colored and reflective. The word "Space" is overlaid in large white text in the lower-left quadrant.

# Space



# Performan

**The Schindler 5400 does the job.**

It is up to us to ensure that you will enjoy a quick, absolutely reliable, and quiet ride. This elevator makes an impression.





# You want more? Then you have come to the right place.

## Multifunctional use

Do you need an elevator system for a building with up to 30 stops, which offers superior performance and an exceptional look? Then you have found the answer in the Schindler 5400. The highly flexible elevator was designed specifically for commercial buildings, office complexes, and public facilities, such as airports.

## Modular components

The Schindler 5400 was developed with consistent system engineering and maximum standardization in mind. The result is a modular passenger elevator based on state-of-the-art prefabricated components. Naturally, this system does not require a machine room, unless you want one, of course.

## Modest space requirements

The Schindler 5400 saves and optimally utilizes valuable space in the building. Due to variable specifications, we can provide the largest possible cabin.

## Innovative operation

At your request, we will install our brand new system architecture for elevator operation and access control with which passengers select their destination before they enter the elevator. In addition, the system is efficient and user-defined so as to be available to certain passengers at certain times.

## Controlled operation

We monitor your system 24 hours a day, 365 days a year, which allows us to correct any malfunction before it can cause problems, around the clock, including nights.

## Frugal energy consumption

The elevator complies with all relevant statutory safety and fire protection requirements and standards. The Schindler 5400 is frugal in its energy consumption, which keeps operating expenses down. You will feel the difference.

## Custom-made design

You have absolute freedom in selecting a high-quality cabin interior designed for a professional environment. We offer anything you might want, from standard design to custom-made models, tailor-made according to your needs. No effort is too great for us to ensure that every last detail of the elevator will match its surroundings and meet your expectations.

## Efficient planning process

The Schindler 5400 saves time and money due to an efficient planning process, fast installation, and uncomplicated start-up, whether you require a single system or a group of up to six elevators.

## Note

Specifications, options, and colors are subject to change.

All cabins and options illustrated in this brochure are representative only. The samples shown may vary from the original in color and material.

## Key Figures

Capacity	450–1600 kg, 6–21 passengers
Travel height	max. 65 m, max. 30 stops
Entrances	one-sided or two-sided
Door width	700–1400 mm
Door height	2000–2300 mm
Drive	traction, without machine room (configuration including machine room optionally available)
Speed	1.0 / 1.6 m/s
Control	collective control for groups up to 6; registered destination control
Interior	three flexible design programs

# Only flying is better. We guarantee it.

Modern airports are multifunctional service centers. Air traffic, retail stores, restaurants, duty-free shops, office leasing, and parking management – everything under one roof. Countless people have to reach their destinations quickly and efficiently, which requires optimally synchronized traffic patterns, horizontally as well as vertically.

Schindler escalators and Schindler elevators fit perfectly into this lively environment. They are reliable and exceptionally attractive. Modern glass cabins and escalators are a fascinating way of enhancing the appearance of a building complex. A graceful solution.





I like the busy atmosphere at the airport. There's always something going on.



It's my job to keep moving. Travelling is part of it.



# Outstanding components for an outstanding product.

Drive	Load capacity		Speed		Travel height max.		Number of stops max.		Nominal rating		Nominal current		Car			Doors		Shaft	
	GQ kg	Passengers	*VKN m/s	HQ m	ZE	PMN kW	INN A	*2 BK mm	*2 TK mm	*3 HK mm	Type	*4 BT mm	*3 HT mm	*5 HSG mm	*6 HSK mm				
Rope*1	450	6	1,0	35	30	4,2	15	850–1200	1000–1450	2200–2400	T2/C2	700–1100	2000–2300	1400	HK+1300				
			1,6	65		7,6	20							1500	HK+1400				
	630	8	1,0	35	30	4,2	15	850–1550	1000–1850	2200–2400	T2/C2/C4	700–1400	2000–2300	1400	HK+1300				
			1,6	65		7,4	22							1500	HK+1400				
	800	10	1,0	35	30	6,8	23	850–1900	1000–2250	2200–2400	T2/C2/C4	700–1400	2000–2300	1400	HK+1300				
			1,6	65		11,9	34							1500	HK+1400				
	1000	13	1,0	35	30	6,8	23	850–2100	1000–2700	2200–2400	T2/C2/C4	700–1400	2000–2300	1400	HK+1300				
			1,6	65		11,9	34							1500	HK+1400				
	1275	17	1,0	35	30	10,8	33	1000–2100	1350–2700	2200–2400	T2/C2/C4	700–1400	2000–2300	1400	HK+1300				
			1,6	65		18,9	47							1500	HK+1400				
	1600	21	1,0	35	30	10,8	33	1200–2100	1550–2700	2200–2400	T2/C2/C4	700–1400	2000–2300	1400	HK+1300				
			1,6	65		18,9	47							1500	HK+1400				

GQ Load capacity  
VKN Speed  
HQ Travel height  
ZE Number of stops  
PMN Nominal rating  
INN Nominal current

\*1 With or without machine room

\* 2.5 m/s available on request

BK Car width  
TK Car depth  
HK Car height

\*2 Car dimensions in 50 mm increments. See page 14 for possible combinations.

\*3 Other dimensions available upon request.

T2 Telescope door (two-part, 700–1100 mm), in 100 mm increments

C2 Center-opening telescope door (two-part, 700–1100 mm), in 100 mm increments

C4 Center-opening telescope door (four-part, 800–1400 mm), in 100 mm increments

BT Door width

HT Door height

\*4 Max. BK –100

HSG Shaft pit depth  
HSK Clear overhead below lifting beam

\*5 Smaller shaft pit depth on request

\*6 With balustrade of 700 mm on car top.

Number of entrances one or two (opposing)

Number of rides: 180 per hour

Power supply: 400 V

Optional: 230 V

Shaft width/depth: in the planning section on pages 26 and 27 the ranges shown reflect typical elevator situations.

**Cabin**

Efficient planning means optimally using the available space. The cabin of the Schindler 5400 is custom-made to ensure that it fits perfectly in width, depth, and height. Cabin dimensions are flexible and available in 50 mm increments.

**Doors**

Doors are made to order with two or four panels, which open centrally from the left or the right. Variable, continuously adjustable door opening and closing cycles reduce waiting times and transport more passengers within a shorter time. A very powerful system.

**Standards**

The Schindler 5400 is certified according to Lift Directive 96/16/EC and conforms to all relevant standards.

- EN 81-28 Remote emergency calling system for passenger and cargo elevators
- EN 81-70 Accessibility of passenger elevators including persons with disabilities (optional)
- EN 81-71 Protective measures against intentional destruction (vandal-proof operator panels and cabin interior) (optional)
- EN 81-72 Fire department elevator (optional)

**Environment**

The Schindler 5400 meets the requirements of ISO 14001 and offers very favorable energy consumption rates. It is environmentally friendly in design and operation.

**Monitoring**

To prevent problems, we permanently monitor the Schindler 5400 in our headquarters, 24 hours a day, 365 days a year.

# Generous and space-saving at the same time.

## Cabin area and load capacity

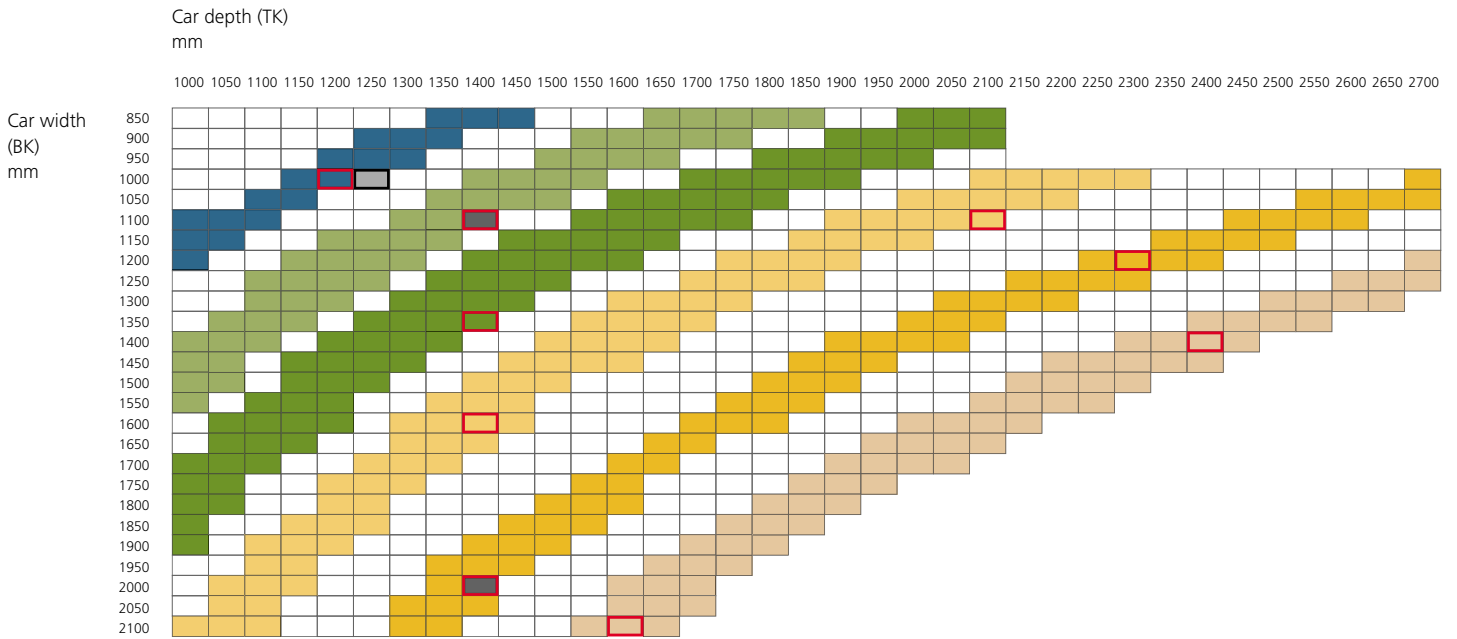

One-sided entrance, changes in dimensions of door-type width.

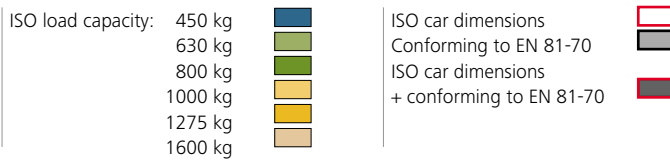

The minimum required cabin area is defined by statutory regulations based on the expected number of passengers and the load capacity.

With the flexible cabin dimensions of the Schindler 5400 you can get the most out of the available space under any circumstances.

**The Schindler 5400 is an electromechanically operated elevator which runs at high speed – up to 1.6 m/s. It saves a lot of space in the building because a machine room is not needed and due to the reduced headroom height. These advantages cannot be overlooked.**

**Drive**

The high-performance permanent-magnet drive of the Schindler 5400 is gearless, which increases efficiency. The motor is relatively small and runs noiselessly. A comfortable, smooth ride without vibration is guaranteed, especially as a result of central suspension and variable frequency control. The elevator has excellent stopping accuracy, is economical in its energy consumption, and subject to minimum heat emission.

**Control**

The microprocessor control of the Schindler 5400 optimally meets a wide range of requirements, both as an individual system and in groups of up to six elevators. Choose between the following standard controls: pick-up, up/down collective, or collective-selective. More than 100 standard control options are available for individual configuration. Rides can also be controlled by key switch or card reader.

**Registered destination control**

Optionally, we will install the unique Schindler Miconic 10 registered destination control. It analyzes the transportation volume of the complete system and assigns the most appropriate car to every passenger, which results in short waiting times and fast rides. The transportation rate of multiple elevators can be improved by synchronizing the group.

Our innovative SchindlerID technology can also be applied with the Miconic 10 registered destination control. SchindlerID represents an entirely new system architecture for elevator operation and access control. Passenger transportation is controlled based on demand and target group. Passengers select their destination before they enter the elevator. Personal profiles are stored on a badge.

The control is installed on the top floor adjacent to the shaft door to save space.



# Creativity as far as the eye can see – an elevator without limits.

Schindler 5400 – top quality also in design. The Trafalgar standard interior design program offers a host of colors and materials for you to choose and combine individually.

The Kensington program goes even further. There is no limit to your creativity. We will deliver precisely what you expect.

The same is true for the Soho design program. Simply let your imagination run away with you to get the glass cabin you really want.

## Design examples



### Trafalgar

Walls: Stainless steel brushed  
Ceiling: Mirror polished  
Floor: Wood laminate Beech  
Lighting: Indirect  
Mirror: Clear glass, full-height, rear wall  
Handrail: Orthogonal, aluminum  
Corner profiles: None



### Kensington

Walls: Marble Fior di Pesco  
Ceiling: Mirror polished  
Floor: Marble Noir Saint Laurent  
Lighting: Halogen spots  
Mirror: Smoked glass, half-height, rear wall  
Handrail: Orthogonal, aluminum  
Corner profiles: Frankfurt Gray



### Soho

Walls: Glass  
Ceiling: Mirror polished  
Floor: Stone Black  
Lighting: Indirect  
Mirror: None  
Handrail: Round, stainless steel  
Corner profiles: None

Trafalgar



Kensington

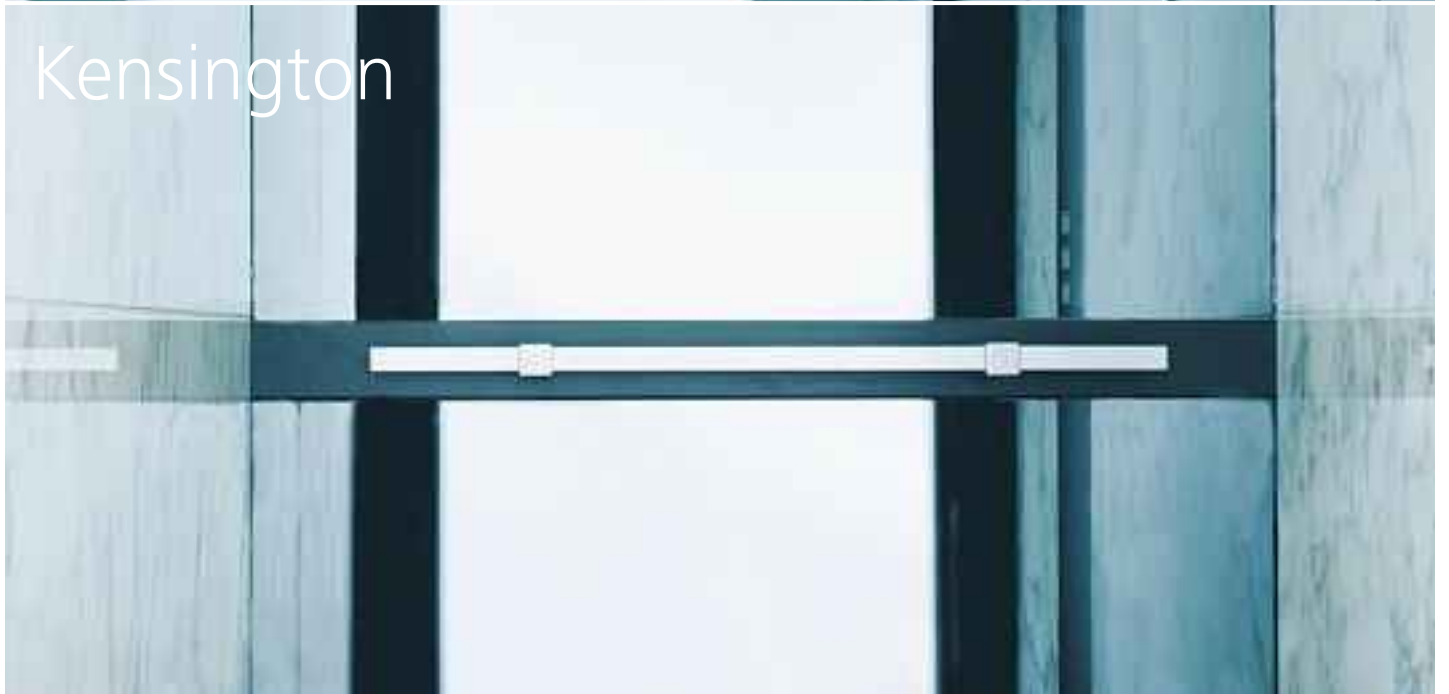

Soho



















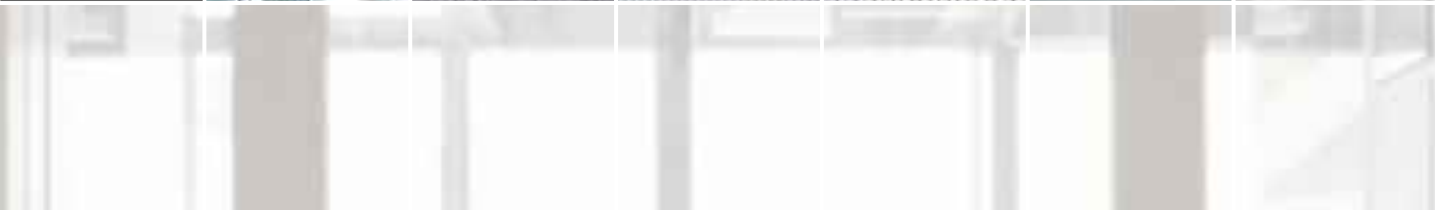
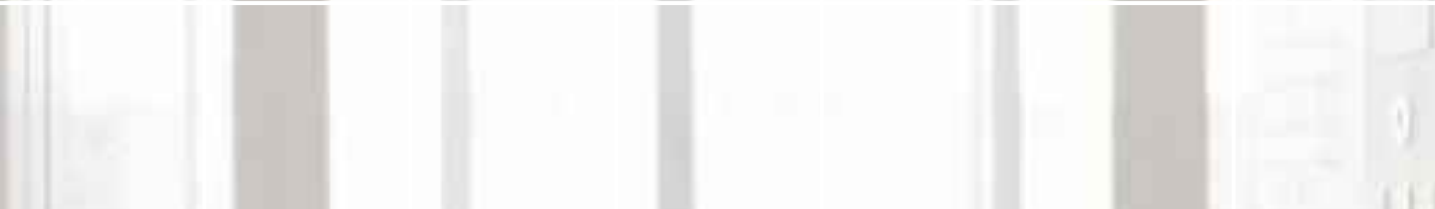



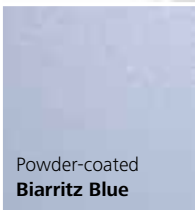
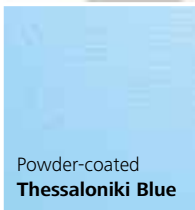

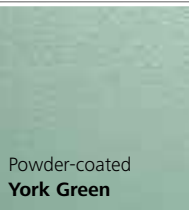





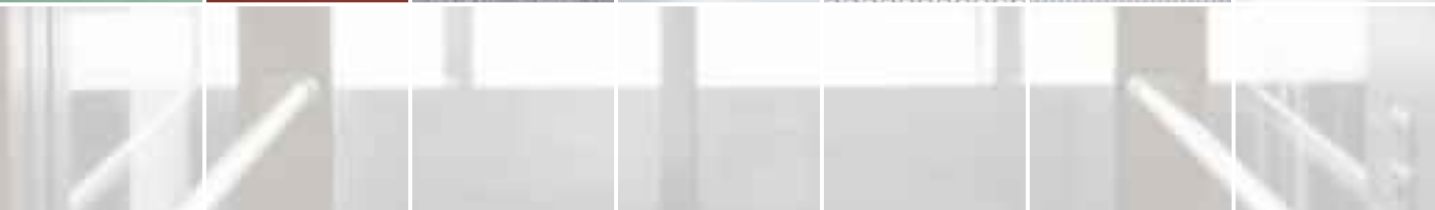

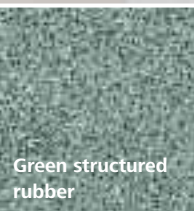

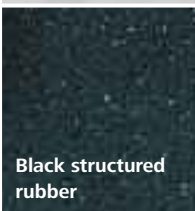
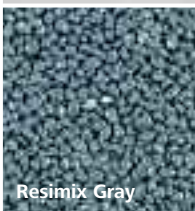
# Trafalgar and Kensington. High-quality colors and materials for a sophisticated look.

The benefits of the Trafalgar design program are twofold: A vast variety of interior design options combined with the advantages of factory standardization. You can mix and match what you like best of the carefully selected color shades and materials. Stainless steel, powder-coated, laminate, granite, rubber, or wood are available in a broad range of colors and textures. At your request, we will additionally install horizontal or vertical style elements\*, mirrors, and a handrail. You can even select the operating panel to create an individual look for a sophisticated environment.

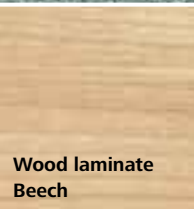
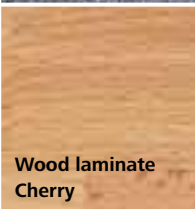
The Kensington design program is custom-made from A to Z to satisfy any need. The cabin interior is completely or partly made to order in the colors and materials you select. You can even choose the operating panel. The appearance of the cabin will be designed according to your personal expectations. This elevator meets any challenge.

\* Corner profiles can be installed if the distance between door and side wall is not less than 90 mm.

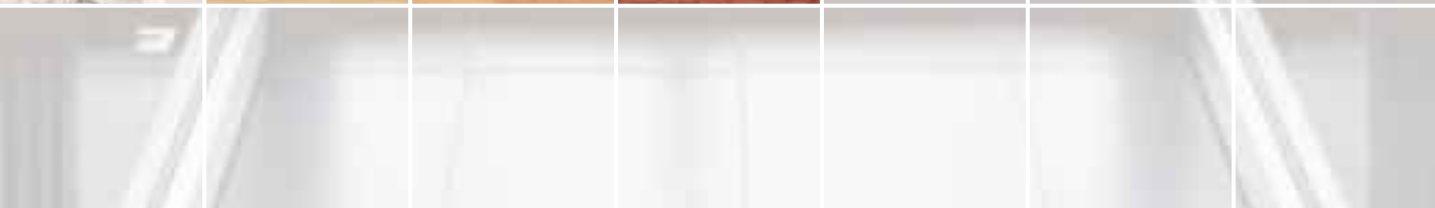
<p>Walls Door Frames</p>	 <p>Walls Door Glass</p>	 <p>Frames Stainless steel brushed</p>	 <p>Frames Stainless steel linen</p>	 <p>Frames Stainless steel Dama pattern</p>	 <p>Frames Powder-coated Basel Gray</p>	
						
						
<p>Ceiling</p>	 <p>Powder-coated Bergen White</p>	 <p>Powder-coated Frankfurt Gray</p>	 <p>Powder-coated Basel Gray</p>	 <p>Powder-coated Biarritz Blue</p>	 <p>Powder-coated Thessaloniki Blue</p>	 <p>Powder-coated Glasgow Green</p>
 <p>Powder-coated York Green</p>	 <p>Powder-coated Hamburg Red</p>	 <p>Stainless steel brushed</p>	 <p>Mirror polished</p>	 <p>Stainless steel Dama pattern</p>	 <p>Stainless steel linen</p>	
						
						
<p>Floor</p>	 <p>Green structured rubber</p>	 <p>Gray structured rubber</p>	 <p>Black structured rubber</p>	 <p>Resimix Gray</p>	 <p>Resimix Black</p>	 <p>Stone Black</p>
 <p>Stone White</p>	 <p>Wood laminate Beech</p>	 <p>Wood laminate Cherry</p>	 <p>Wood laminate Mahogany</p>	 <p>Prepared for local floor</p>		
						

# Soho.

## Transparence to create a functional technical ambiance.

The Soho design program proves the point. Cabins made entirely or partly of glass are extraordinarily attractive. The transparence is utterly fascinating and provides the building complex with technical and functional refinement. Glass cabins can be installed in a glass shaft, inside or outside the building. Inside, glass cabins may not need a shaft.

Schindler glass cabins comply with the same standards and requirements as all other cabins. Multilayer safety glass for the doors and a light curtain for passenger comfort ensure that the system is safe. A unique elevator with special appeal.

### Examples of glass configuration

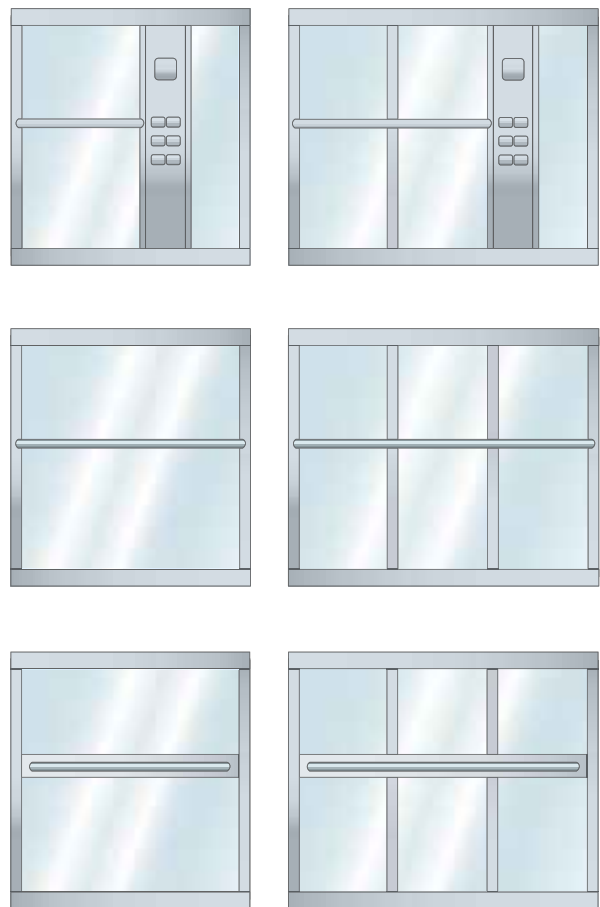

Glass across full width  $\leq$  2100 mm

# Gigantic even in the smallest detail. Our communication elements.

## **Car operating panels and call buttons**

The elegant car operating panel of the Schindler 5400 extends over the entire car height. It is set into and aligned flush with the car wall and available in a variety of materials and styles, from anthracite and stainless steel to mirror-polished steel and silver.

## **Lighting**

Our standard program offers a selection of three types of car lighting: halogen spots in the corner profiles, halogen spots in the ceiling, or indirect lighting in the lowered ceiling, all generating an exceptionally pleasant light.

## **Mirrors**

Full-height or half-height mirrors of clear or smoked glass can be installed on the side walls or on the rear wall.

## **Handrail**

To provide support, the elevator can be equipped with a rounded or square handrail in aluminum, stainless steel, maple, or mahogany.

## **Corner profiles**

Corner profiles add the finishing touch to your elevator. They are available in anthracite, stainless steel, mirror polished steel, or silver to match the operating panel.



# Well thought out from A to Z – from planning to installation.



## **Planning**

The Schindler computation programs quickly find the most efficient solution for any traffic situation. Parametric outline, small-size grid, and the fewest possible connection points to the building ensure that planning is easy and efficient.

The Schindler 5400 requires no machine room, although it can, of course, accommodate one, if needed. Planning is simpler without a machine room. Only one room, the elevator shaft, has to be designed. Standardized plans facilitate the process.

One site visit is enough for us to record the data. An easy and efficient procedure.

## **Ordering**

The Schindler 5400 is sophisticated, yet simple in design. The key factors are quickly established. Complex specifications are not necessary, and therefore, it is easy to place an order. The right product to cover your needs is quickly selected. Remarkably easy.



### **Delivery**

The Schindler 5400 is delivered complete and ready assembled, and not before the building is ready for installation.



### **Installation**

Standard interfaces and uncomplicated cabling are the prerequisites for a fast and effortless start-up. Simply a well-thought-out process.

Our goal is to save you as much time and money as possible. Therefore, we have developed an efficient system consisting of planning process, purchase order, delivery, and installation of the Schindler 5400. We avoid all unnecessary paperwork and needless telephone calls. Information is accessible at all times, even externally.

We communicate as directly as possible with our customers and business partners. When practical, we use the Internet.

We supply elevators that are easy to buy, easy to operate, and easy to service.

# Planning is not everything, but nothing works without planning.

## Planning information

Machine room-less traction elevator with frequency controlled drive  
450–1600 kg capacity, 6–21 passengers.

Drive	Load capacity		Passengers max.	Speed	Car			Doors			Shaft			
	GQ kg	VKN m/s			BK mm	TK mm	HK mm	Type	BT mm	HT mm	*1 BS mm	*1 TS mm	*3 HSG mm	*2/3 HSK mm
Rope	450	6	1,6	1000	1200	2200	T2	800	2000	Z1: 1500 Z2: 1700	Z1: 1600 Z2: 1750	1500	3600	
	630	8	1,6	1100	1400	2200	T2	900	2000	1650	Z1: 1850 Z2: 1950	1500	3600	
	800	10	1,6	Z1: 1350 Z2: 1200	1400	2200	T2	1100 900	2000	Z1: 1950 Z2: 1700	Z1: 1850 Z2: 2150	1500	3600	
	1000	13	1,6	1100	2100	2200	T2	900	2000	1650	Z1: 2500 Z2: 2650	1500	3600	
	1275	17	1,6	1200	2350	2200	T2	1100	2000	2000	Z1: 2750 Z2: 2900	1500	3600	
	1600	21	1,6	1400	2400	2200	C4	1300	2000	2150	Z1: 2800 Z2: 2950	1500	3600	

GQ	Load capacity	BK	Car width	T2	Telescope door	BS	Shaft width
VKN	Speed	TK	Car depth	C4	Center-opening telescope door	TS	Shaft depth
HQ	Travel height	HK	Car height	BT	Door width	HSG	Shaft pit depth
				HT	Door height	HSK	Clear overhead below lifting beam
						*1	Z1 = 1 entrance Z2 = 2 entrances
						*2	With balustrade of 700 mm on car top.
						*3	by VKN = 1,0 m/s HSG and HSK can be reduced by 100 mm each

HEmin = HT + 600 mm for one-sided entrances  
HEmin = 300 mm for staggered opposite entrances

For additional information, such as proposals, construction plans, and pricing, please contact our Sales Department directly.

## Height and plan view

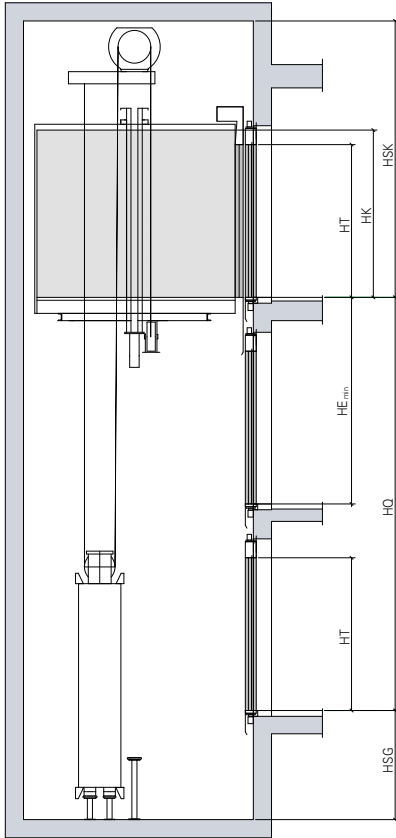

One-sided entrance

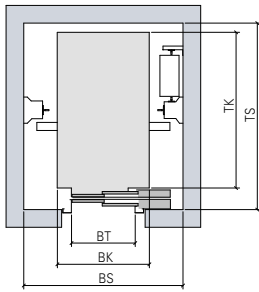

One-sided entrance  
Telescopic door

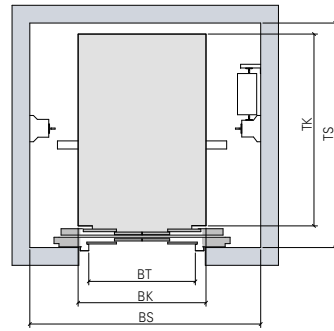

One-sided entrance  
Center-opening telescope door (four-part)

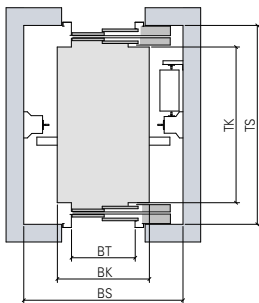

Two-sided entrance  
Telescopic door

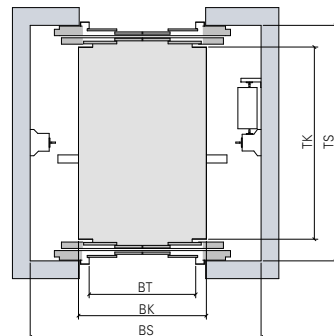

Two-sided entrance  
Center-opening telescope door (four-part)

# Our elevators are on the fast track – and so are we.

For additional information and the location  
of our subsidiary nearest you, please contact:

**[www.schindler.com](http://www.schindler.com)**